

Use

Measuring HSK spindle drive keys and radius.

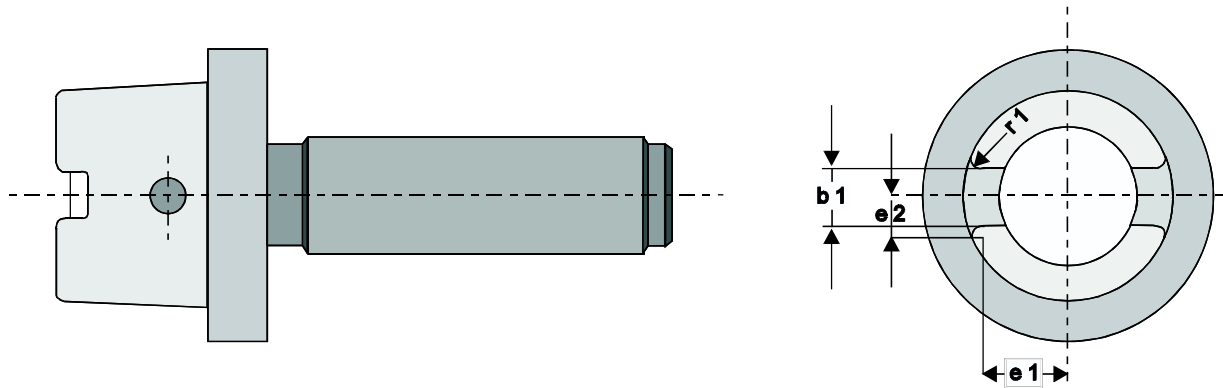

Spindle taper per DIN 69 063 type A and C	Complete set in wooden case: 2 taper plug gages Ref.No.	b 1 ± 0.05	e 1	e 2	r 1 + 0.025 - 0.025
HSK 32	284.001	6.8	8.905	4.903	1.5
HSK 40	284.002	7.8	11.081	5.903	2.0
HSK 50	284.003	10.3	13.997	7.648	2.5
HSK 63	284.004	12.3	18.110	9.150	3.0
HSK 80	284.005	15.8	22.073	11.898	4.0
HSK 100	284.006	19.78	27.561	14.888	5.8
HSK 125	284.007	24.78	35.580	18.388	6.0
HSK 160	284.008	29.78	44.538	22.888	8.0

Description

2 measuring gages in storage case: “go” and “no go” plug gages.

Note

Center deviation of b 1 (0.05 mm) is not measured.

Function

When inserted in the spindle, the “go” gage should be in contact with the plane face. The “no go” gage should not contact the face.