

- For fitting onto machine spindle for holding HSK tools
- Mounting flanges include clamping cartridge, cover ring, and holding screw
- Can be accurately adjusted to concentricity using the adjusting screw on the machine spindle

All dimensions in mm.

D-HSK	D ₁	D ₂	A	kg/lb	Order Number
32	55	61	13	0.40/0.88	355.616.032.000
40	63	70	15	0.60/1.32	355.616.040.000
50	80	87	17	0.90/1.98	355.616.050.000
63	100	108	21	1.60/3.53	355.616.063.000
80	117	125	21	2.40/5.29	355.616.080.000
100	140	150	28	4.50/9.92	355.616.090.000

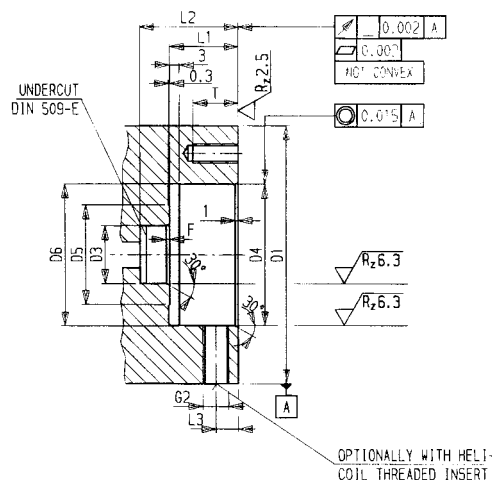
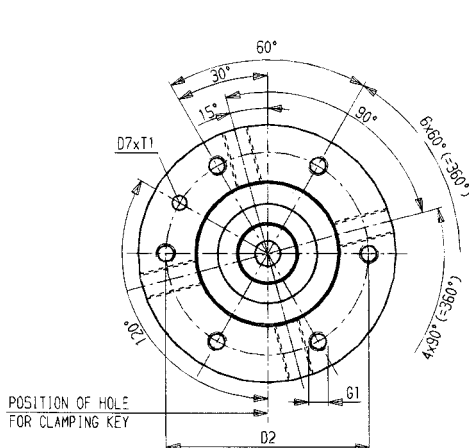

Internal spindle contour

D _{HSK}	D ₁	D ₂ ± 0.1	D ₃ H7	D ₄ F8	D ₅	D ₆ ± 0.2	D ₇	E	L ₁ ± 0.1	L ₂ min.	L ₃	F	G ₁	G ₂	T	T ₁ + 0.5
32	55	42	13	28	22	28.2	4.5	0.4 x 0.2	15.2	24	7	1.0	M5	M4	11	3
40	63	50	15	35	25	35.2	5.0	0.4 x 0.2	18.2	27	7	1.0	M5	M5	14	3.5
50	80	63	18	44	31	44.2	5.0	0.6 x 0.3	21.2	30.5	7	1.0	M8 x 1	M8 x 1	14	3.5
63	100	79	20	56	35	56.2	5.0	0.6 x 0.3	25.2	35.5	8	1.5	M10 x 1	M10 x 1	15	3.5
80	117	96	23	68	43	68.2	6.0	0.6 x 0.3	33.2	43.5	8	1.5	M10 x 1	M10 x 1	15	4.5
100	140	119	29	88	55	88.2	6.0	0.6 x 0.3	43	57	8	1.5	M10 x 1	M10 x 1	20	4.5