

- For fitting onto machine spindle or in standard ISO adapters for holding HSK tools
- Adapter flanges include clamping cartridge, cover ring, and holding screw
- Can be accurately adjusted to concentricity using the adjusting screw on the machine spindle or in the ISO adapter

All dimensions in mm.

D-HSK	D ₁	D ₂	A	L ₁	kg/lb	Order Number
32	60	37	26	13	0.40/0.88	355.615.032.000
40	70	45	30	15	0.60/1.32	355.615.040.000
50	80	55	35	18	0.90/1.98	355.615.050.000
63	100	70	43	22	1.80/3.97	355.615.063.000
80	117	87	50	29	2.70/5.95	355.615.080.000
100	140	110	70	42	4.90/10.80	355.615.090.000

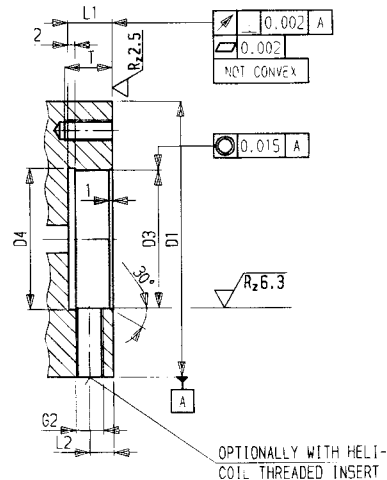
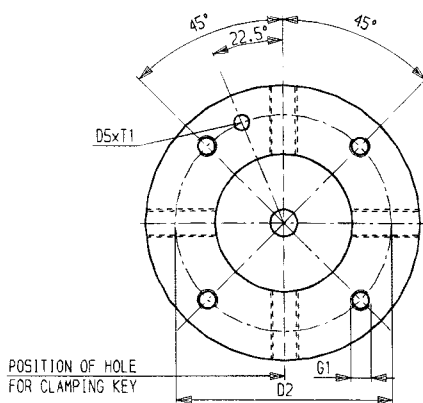

Internal spindle contour

D _{HSK}	D ₁	D ₂ ± 0.1	D ₃ F8	D ₄	D ₅	L ₁	L ₂	G ₁	G ₂	T	T ₁ + 0.5
32	60	44	30	31	4.5	12	7	M5	M8 x 1	11	3
40	70	53	35	36	5.0	12	7	M6	M8 x 1	14	3.5
50	80	63	40	41	5.0	12	7	M6	M8 x 1	14	3.5
63	100	79	50	51	5.0	14	8	M8	M10 x 1	15	3.5
80	117	96	60	61	6.0	14	8	M8	M10 x 1	15	4.5
100	140	119	80	81	6.0	14	8	M10	M10 x 1	18	4.5